

1.4

2.

2.1

2.2

2.3

1		

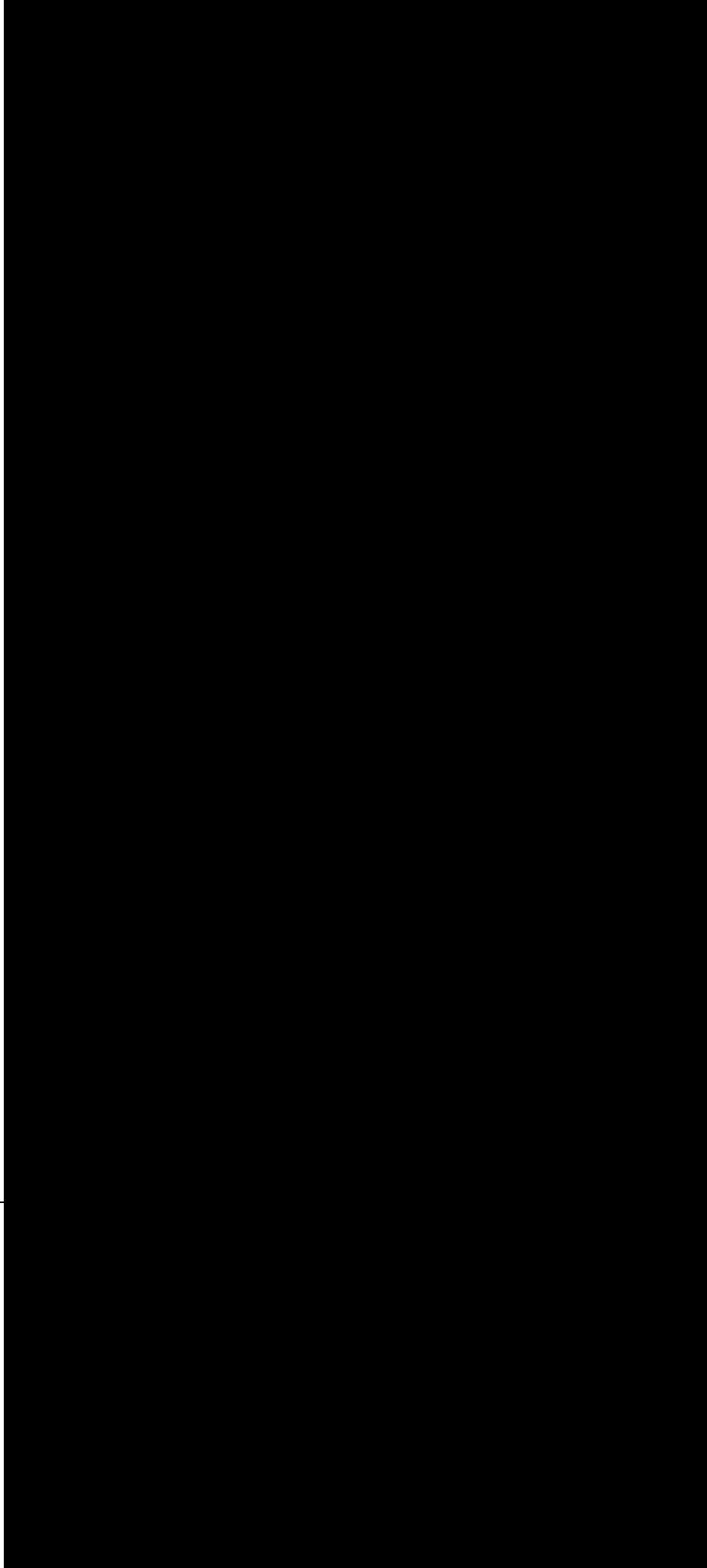

3.

3.1

3.1.1

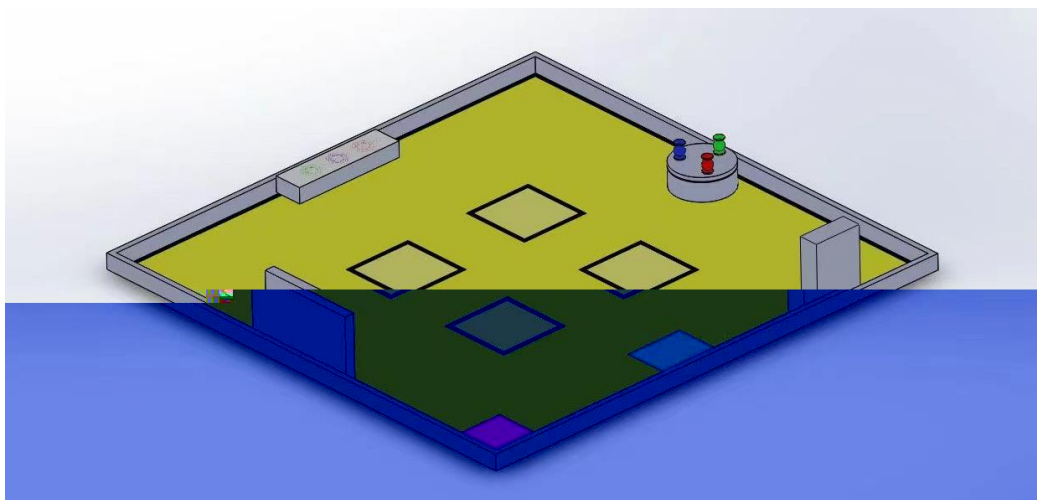
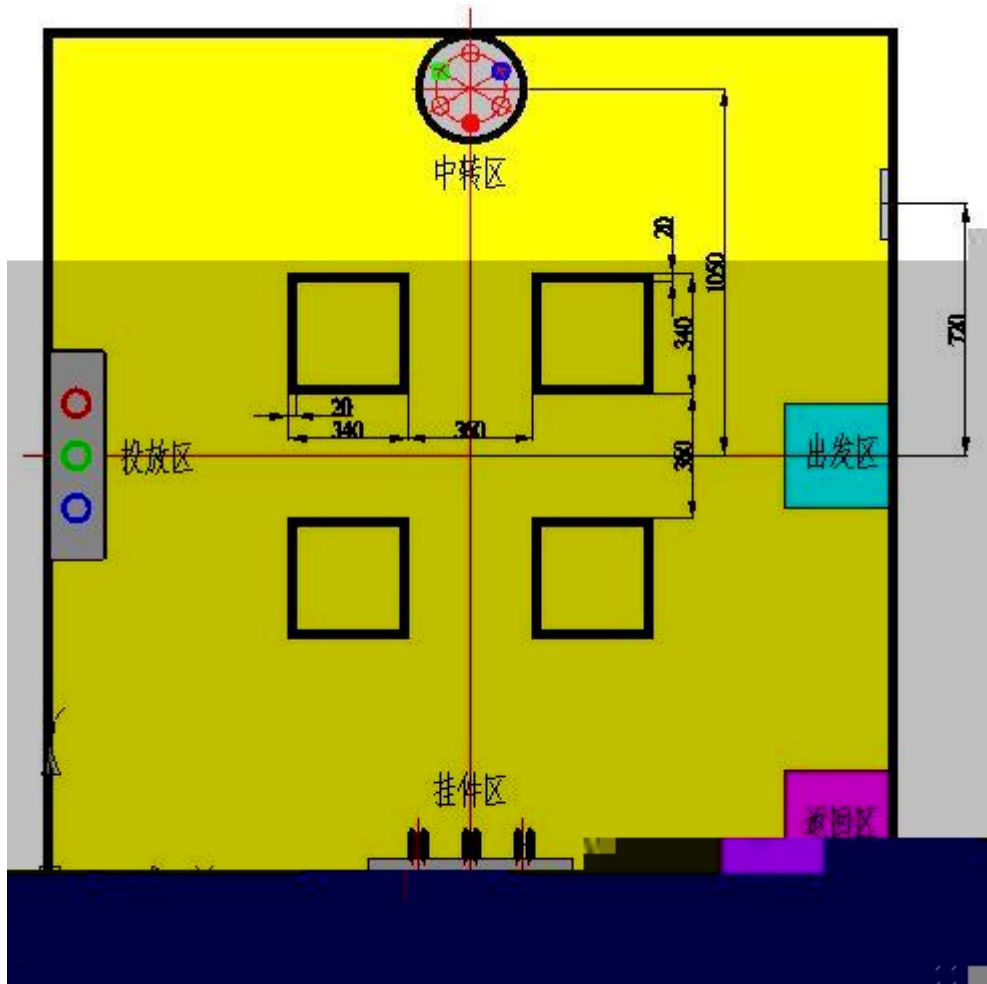

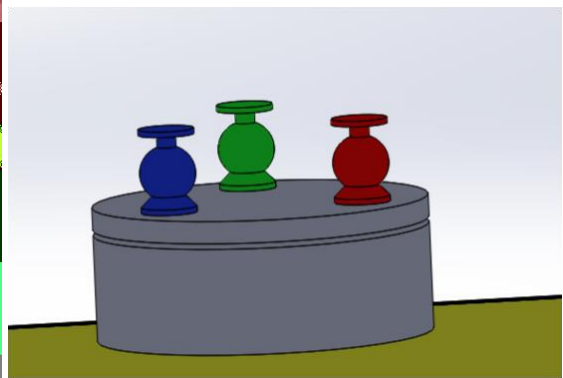
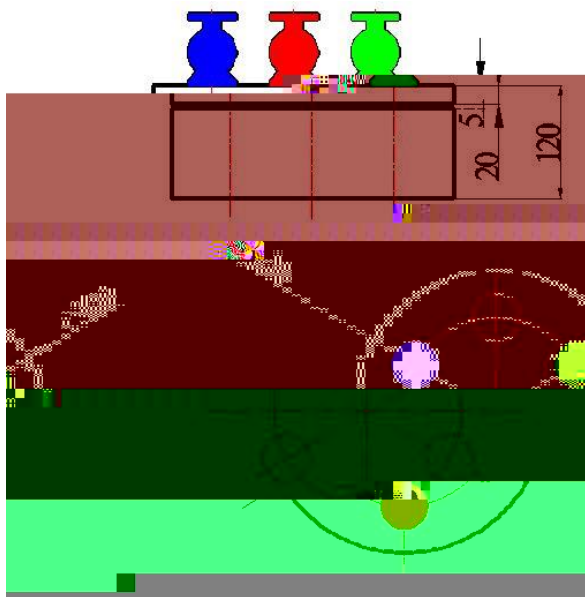

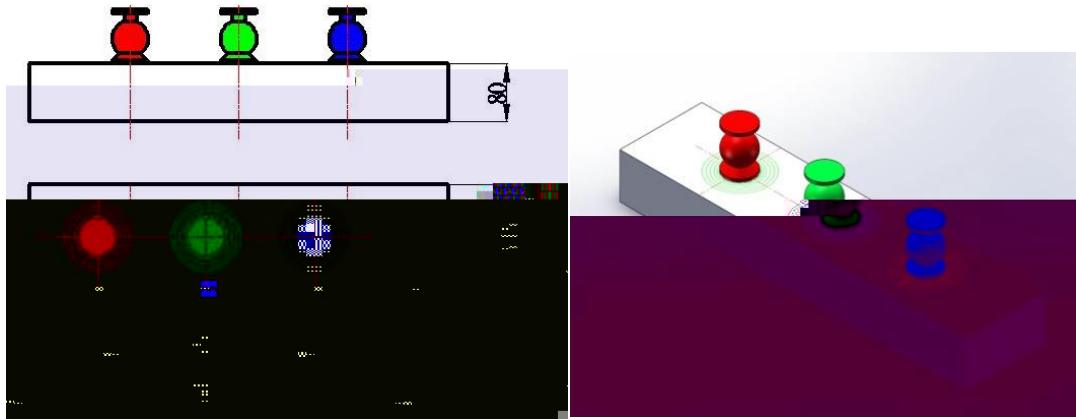

3

2

	1 (1)	2 (2)	3 (3)	4 (4)	5 (5)	6 (6)	6
	+3	1+5	2+7	3+10	4+10	5+10	
	15	10	7	5	3	1	0

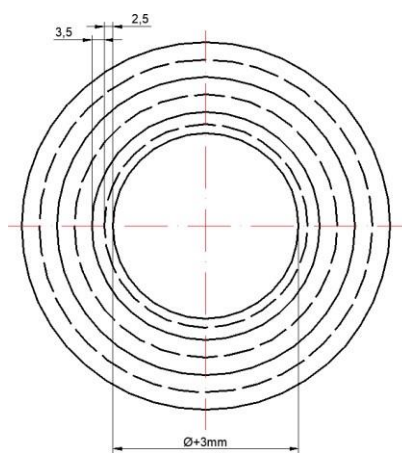

4

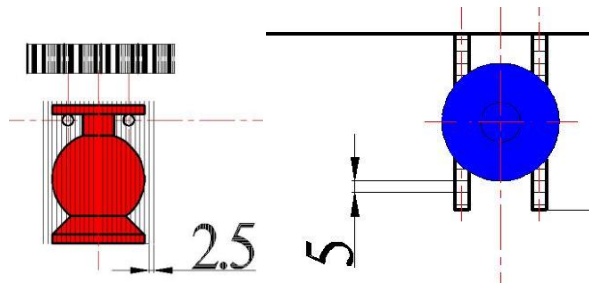
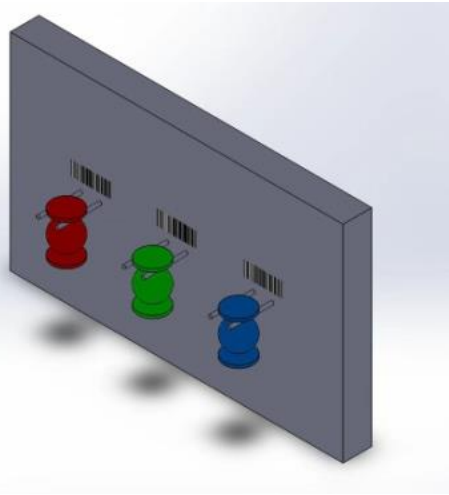
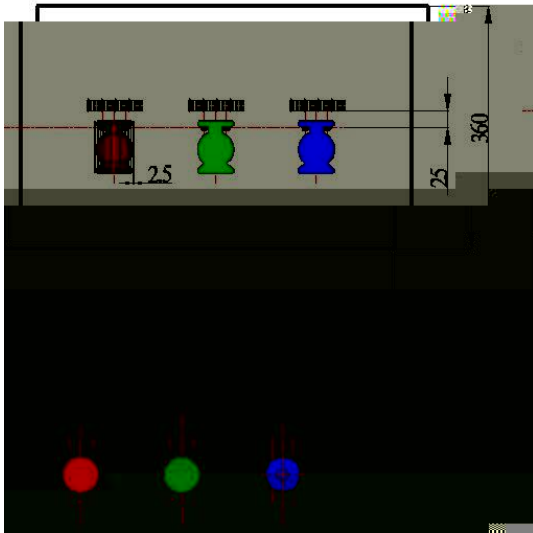

5

3.1.2

2400mm×2400mm

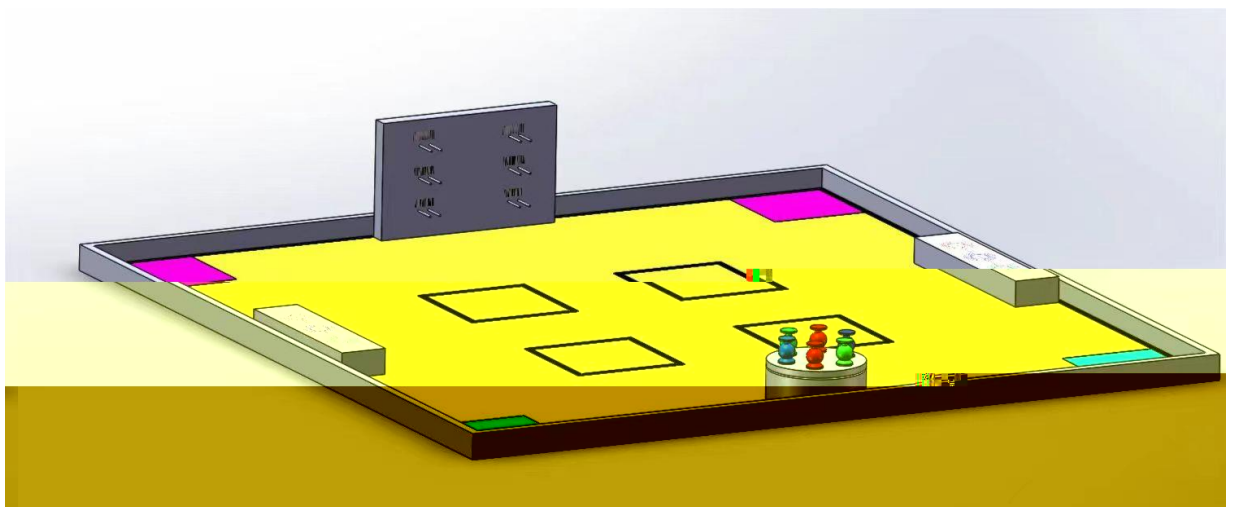
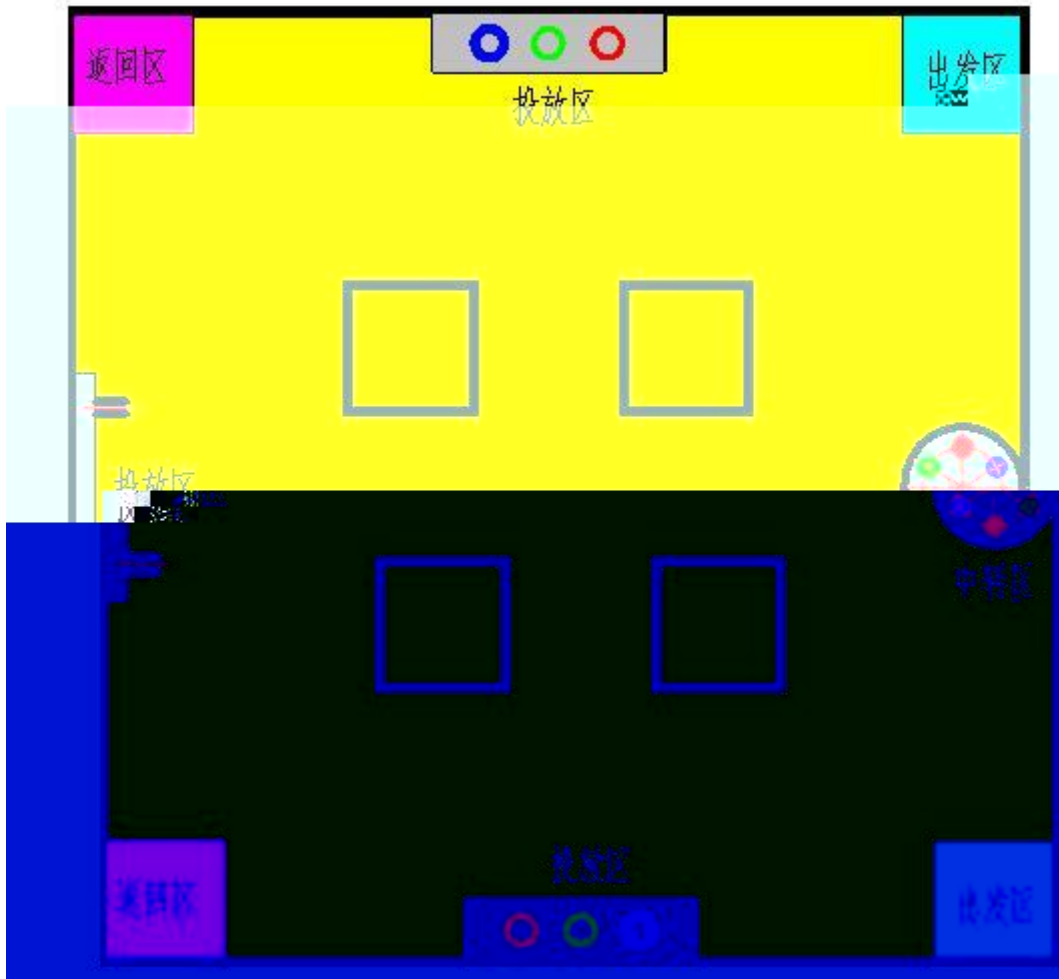

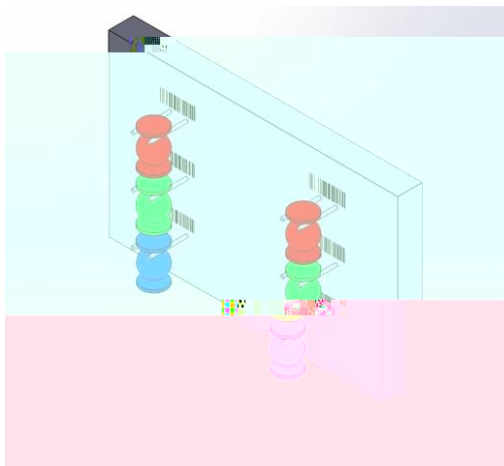
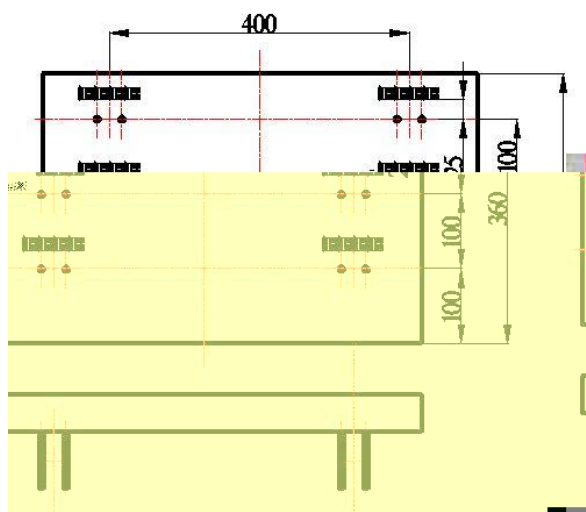

7

3.2

50mm

75mm

50g

3D

ABS

ABS/Red C-21-03

ABS/Green C-21-06

ABS/Blue C-21-04

2

200mm

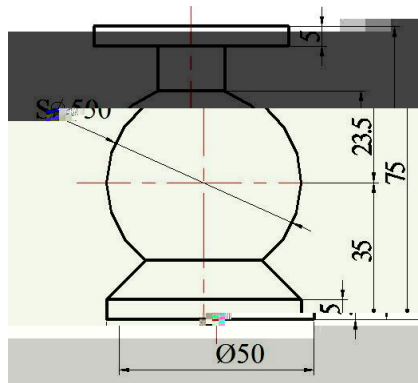

8

50g

3.3

1

3

1 A4

80×80 mm

4.

4.1

4.2

4.2.1

1

3

60%

5.

5.1

5.2

6

1

3

6

5

3

2

1

4

2

5.3

3

3

3

5

C

$$C = 80 \times \text{_____}$$

$$P = A + C$$

